

INSTALLATION INSTRUCTIONS

20' FLS CANOPY

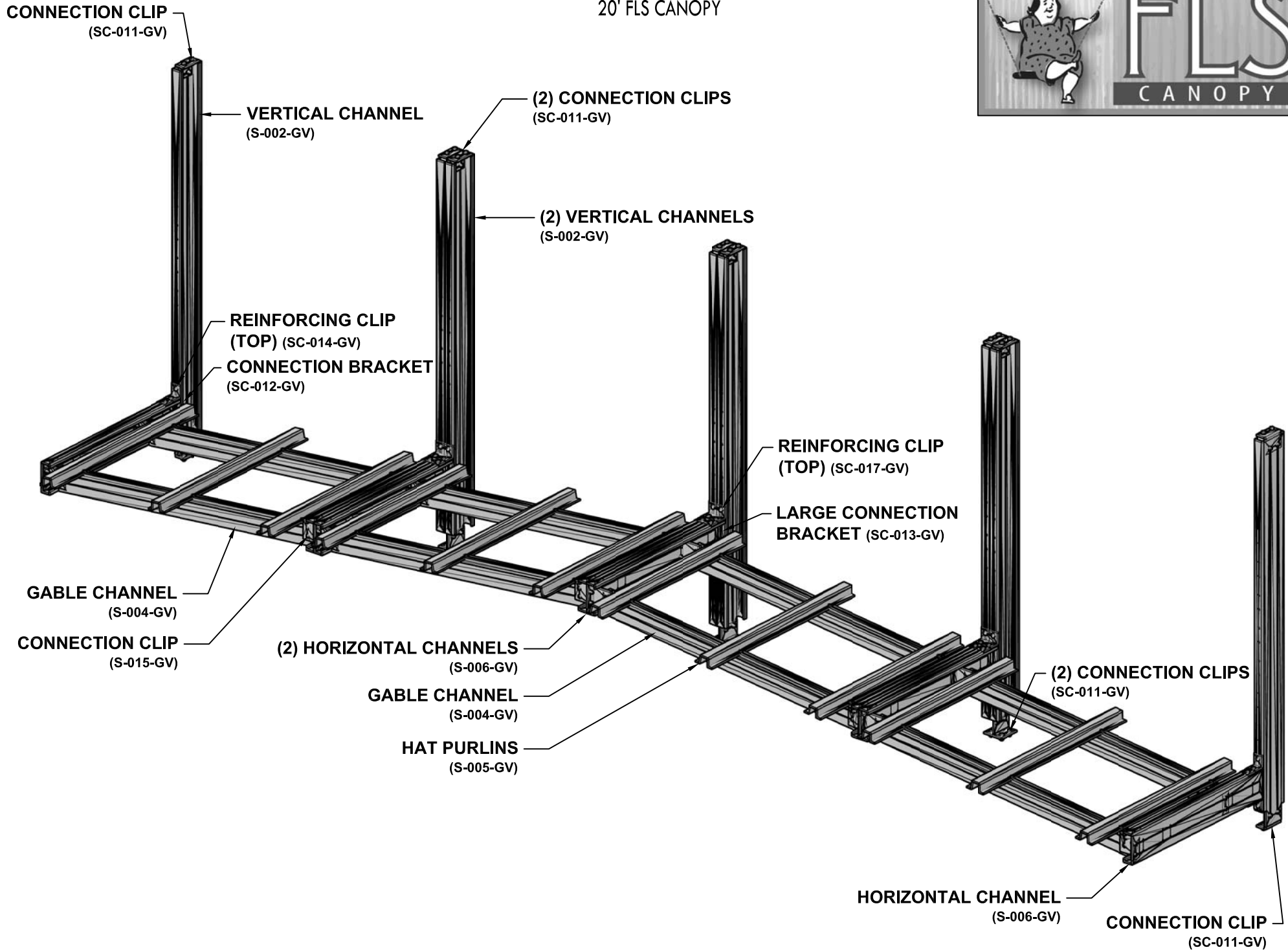



INSTALLATION INSTRUCTIONS

20' FLS CANOPY

20' FLS Canopy

Patent No. 5,299,395 issued 4/5/1994

1. **Identify each of the parts in the "Framing Kit" according to the enclosed packing list.** Most parts are marked with a part number.
2. **Determine location of "FLS Canopy" on building.** Mark the centerline of canopy on girt above door. This usually is the same as the center of the door opening. Draw a line 2'-6" on both sides of the centerline. Locate, center punch and drill the (8) holes as dimensioned in **Figure 1**.

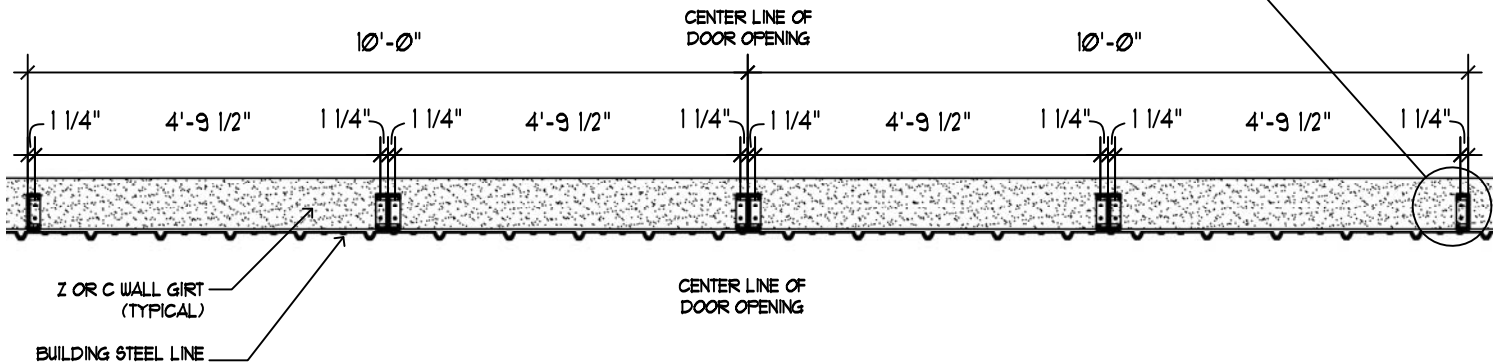
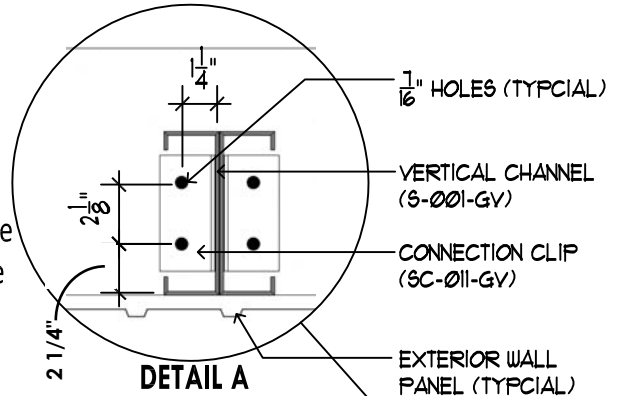

FIGURE 1

3. Installing the Vertical Channels

- a. Measure the distance (H) between girts or girt and eave strut. See **Figure 2**.
- b. If ("H") is less than 6'-1 1/4", deduct 1 1/4" to get the new length of the Vertical Channels. By deducting 1 1/4" you allow for the height of the connection clips. Measure from the end with the tab and cut the end having two holes. See **Figure 3**. For example, if ("H") measures 3'-6", subtract 1 1/4" which leaves 3'-4 3/4". Cut the (2) Vertical Channels to a length of 3'-4 3/4".
- c. Drill (2) 7/16" diameter new connection clip holes in the cut end of the the Vertical Channels. Use the cut off as a template to create new holes.

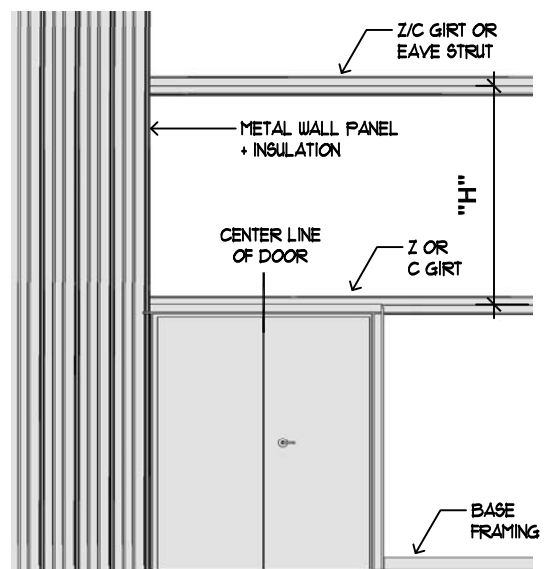

FIGURE 2

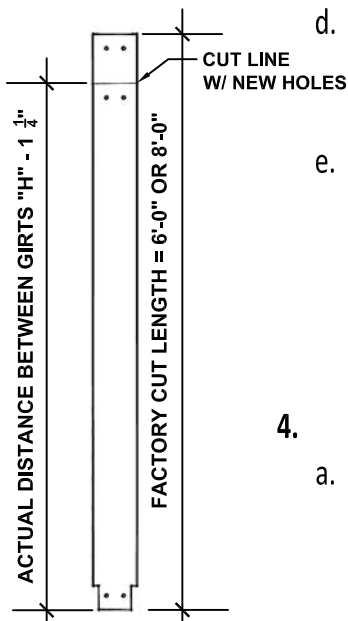

FIGURE 3

- d. Attach the Clips, (Part SC-011-GV), to both ends of the Vertical Channels with (2) $\frac{3}{8}$ " diameter bolts. The 3" leg of the clip attaches to the Vertical Channel.
- e. Using $\frac{3}{8}$ " diameter bolts, attach the tabbed end of the Vertical Channel, open "C" facing toward the center, to the drilled girt holes. Level and plumb the Vertical Channel in both directions. Using the top connection clip, mark the hole locations and drill $\frac{7}{16}$ " diameter holes in the upper girt or eave strut. Bolt together with $\frac{3}{8}$ " bolt/nuts. (Figure 4) Repeat for other Vertical Channel.

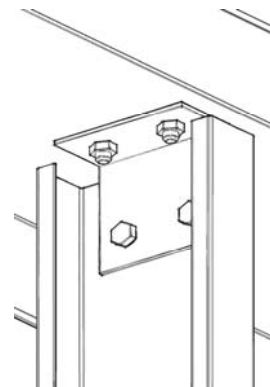

FIGURE 4

4. Installing the Horizontal Channels

- a. Determine the mounting height of your canopy. The Vertical Channel is punched with a variety of holes to choose from.

1. **Figure 5** - Interior Structural Connection Detail - Top Reinforcing Clip (SC-017-GV), Connection Bracket (SC-013-GV) and Bottom Reinforcing Clip (SC-014-GV) (for coastal high wind areas) all connected with $\frac{3}{8}$ " bolt/nuts. Interior support shown. **ALWAYS INSTALL THE TOP REINFORCING CLIP (SC-017-GV).**

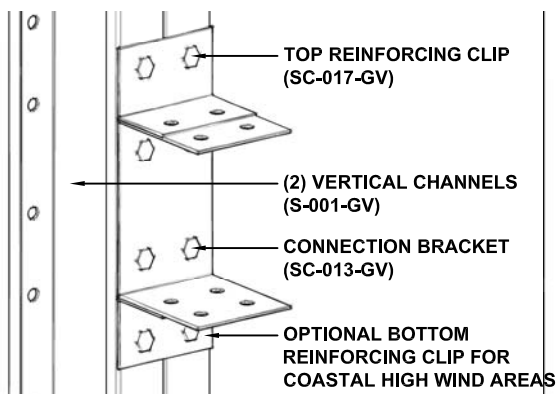

FIGURE 5

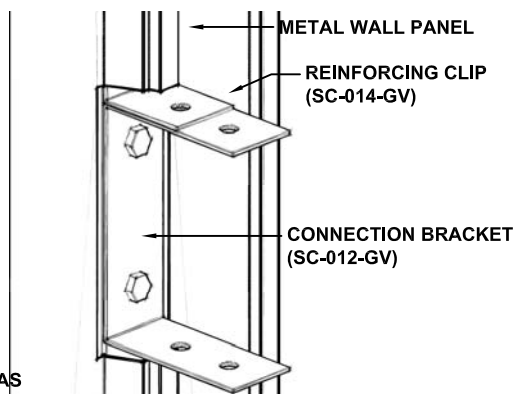

FIGURE 6

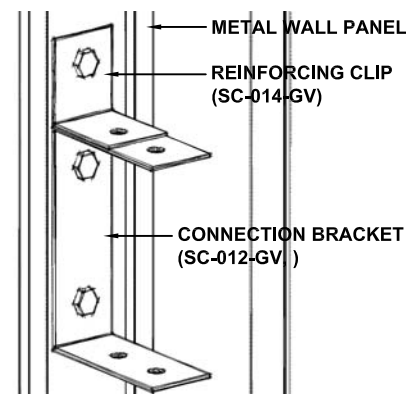

FIGURE 7

2. **Figure 6** - Use your selected holes in the Vertical Channel to drill pilot holes through your metal wall panel. If the pilot hole lands on or near a panel rib, cut a (+/-) 2" x 6" hole to allow the bracket to penetrate through the panel as shown (Figure 6). **ALWAYS INSTALL THE TOP REINFORCING CLIP (SC-014-GV).**
3. **Figure 7** - If your bracket location falls in the flat of the wall panel you may surface mount the Reinforcing Clip (SC-014-GV) and Connection Bracket (SC-012-GV) as shown. You may want to remove some of the batt insulation to allow a tight connection. **ALWAYS INSTALL THE TOP REINFORCING CLIP (SC-014-GV).**

- b. Horizontal Channel (S-006-GV) - **The bottom of the Horizontal Channel is identified by the $\frac{1}{4}$ " holes in the face of the member. These holes are closer to the bottom than the top.** The open part of the "C" should face to the center of the canopy as shown on the cover of the instructions. Level and bolt the Horizontal Channel to the Connection Bracket and Reinforcing Clip as shown in **Figure 8 & Figure 9** using $\frac{3}{8}$ " bolt/nuts.

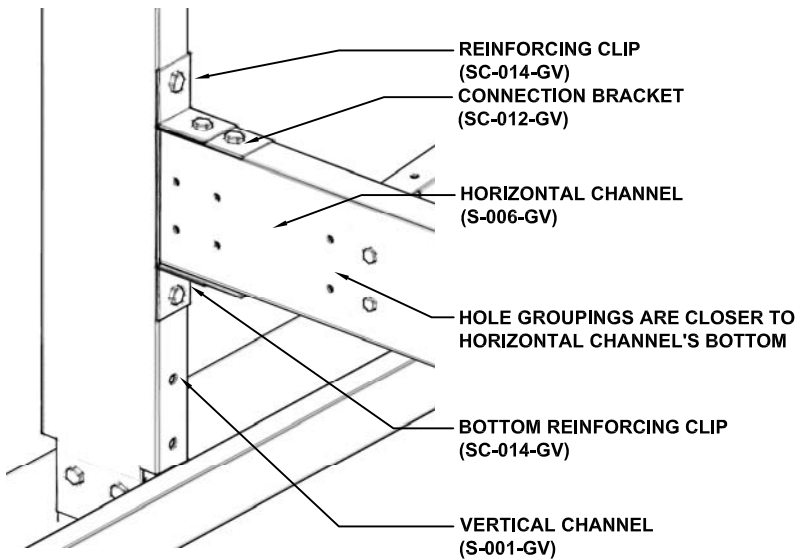

FIGURE 8 - EXTERIOR SUPPORT

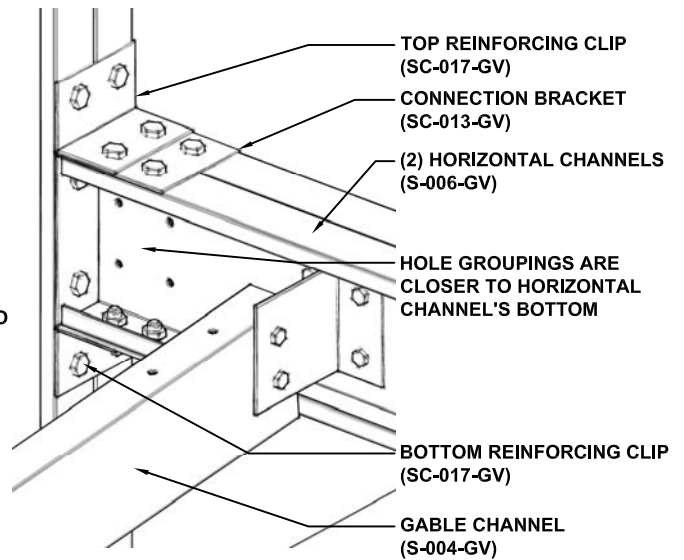

FIGURE 9 - INTERIOR SUPPORT

5. Secondary Framing

- a. **Gable Channels** - Attach (4) gable channels(S-004-GV) as shown in **Figure 10**. Attach to Horizontal Channels using (2) Connection Clips (SC-015-GV) and $\frac{1}{4}$ " bolt/nuts. **Note holes for purlin attachment must be on top of Gable Channels.**
- b. **Hat Purlins** - Attach (6) Hat Purlins (S-005-GV) to the Gable Channels using $\frac{1}{4}$ " bolts/nuts. If necessary, use a channel lock pliers to squeeze the Hat Purlins to allow the holes to line up. See **Figure 10** for a completed FLS frame. Purlins are not punched symmetrically, shorter cantilever toward wall.

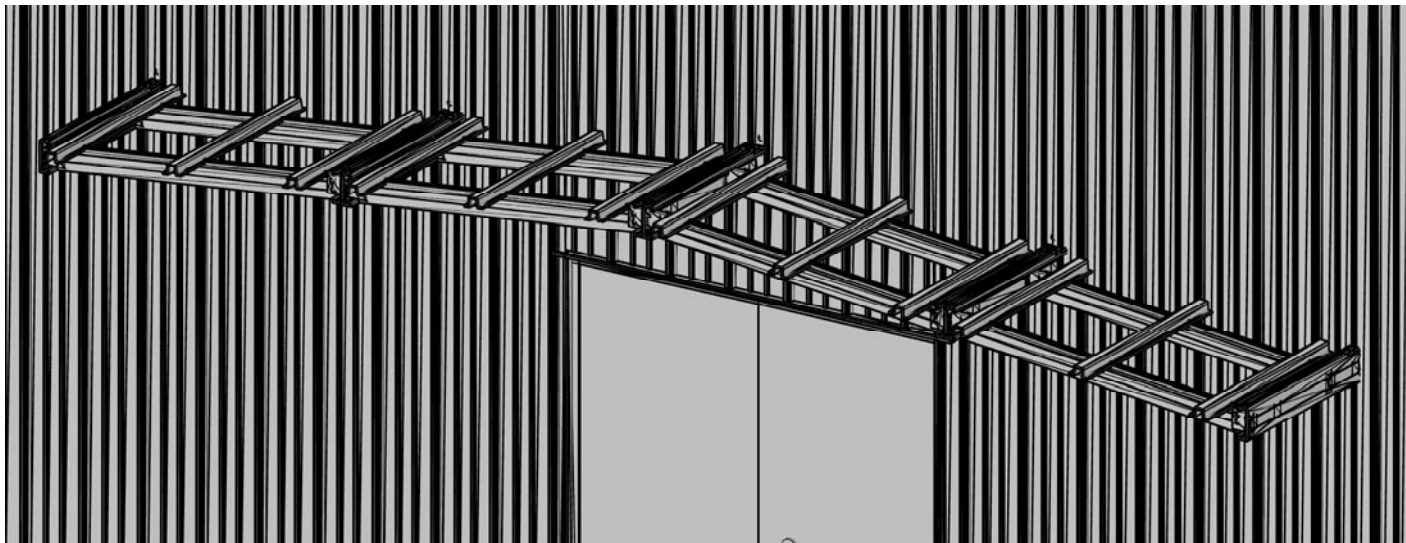

FIGURE 10

6. Roof Panel & Trim

- a. **Standard Transition Flash Installation for "R-Panel" wall panel**
 1. Place the Ridge Roof Sheet and (2) End Roof Sheets on to the Hat Purlins. Center the sheets and slide them against the building wall sheets as shown. Mark each of the wall corrugations at the top of the roof panel per **Figure 11**.
 2. Measure 10' -2 $\frac{1}{4}$ " from the canopy center to where the roof panel will end. Remove roof panels and set aside.

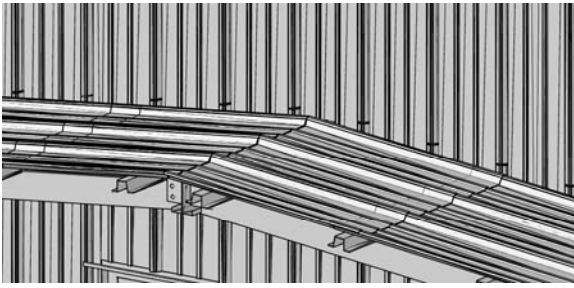

FIGURE 11

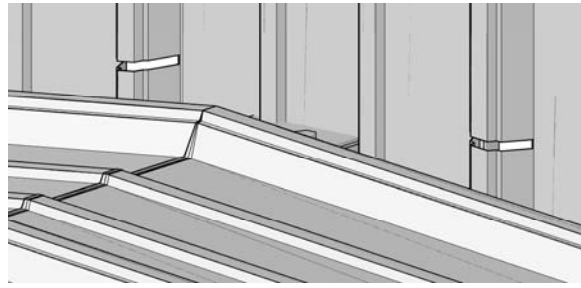

FIGURE 12

3. Cut each of the major ribs as shown in Figure 12 following the roof slope. **Do not cut the minor ribs or the flat of the panel.** If the end of the roof sheet ends on a major rib, only cut the portion of the rib in line with the roof panel.
4. Transition Flashing (T-036-00), 2" x 4" angle flashing, 2" leg down, 4" leg over the roof panel. In the center of the flash, make a single cut in the 2" leg. This will allow the flashing to follow the roof slope. With the flashing centered on the canopy, push the flashing to the wall and mark a vertical lines on the 2" leg on each side of the major ribs. Notch the 2" leg as in **Figure 13**. Trim off any part of 2" leg that interferes with the horizontal channel.

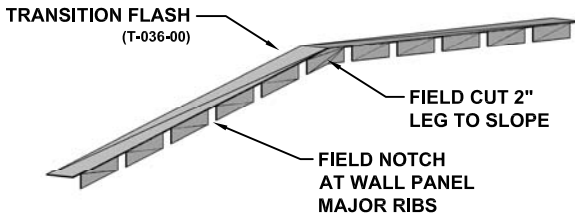

FIGURE 13

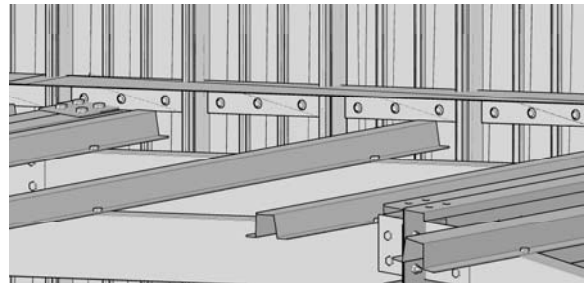

FIGURE 14

5. Using stitch screws (F-052-00) attach the 2" leg to the wall sheet. Locate fasteners 3" on center as close to bend as possible. Place a bead of caulking (not furnished) on top of transition flash following the contour of the wall sheet.

b. Roof Panel & Trim

1. Place the End Roof Sheets back on the Hat Purlins. Slide the sheet toward the wall panel allowing $\frac{3}{4}$ " from the end of the Hat Purlins per **Figure 15**. Align the bottom of the panel with the end of the Transition Flashing. Square panel with canopy framing. Attach Roof Panel to lowest Hat Purlin with Structural Screws per **Figure 15**.

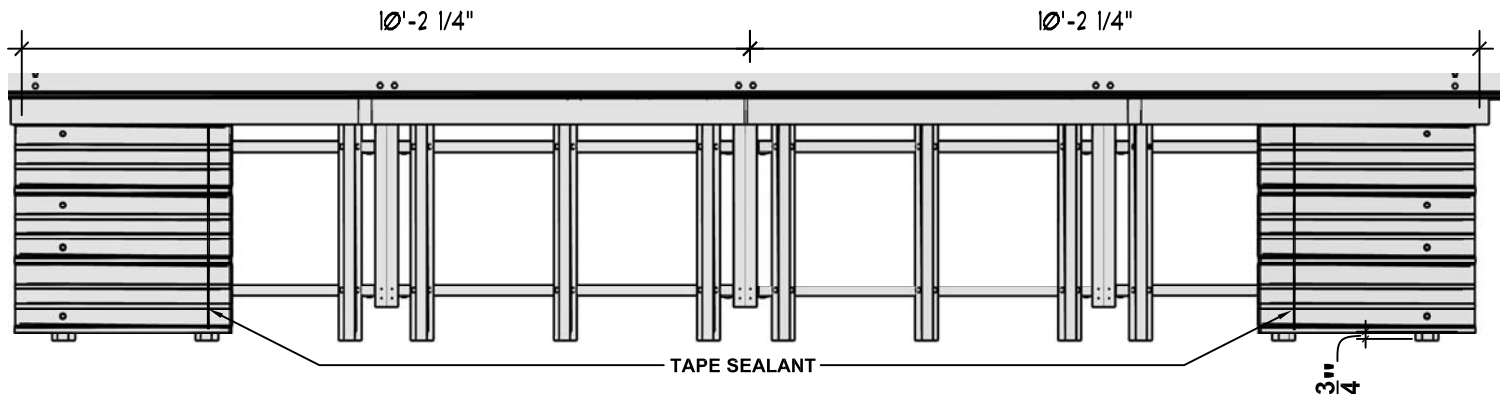

FIGURE 15

- Place a strip of Tape Sealant (M-061-00) across the top of the End Roof Sheets (C-042-00) just below the bottom edge of the second Hat Purlin per **Figure 15**.

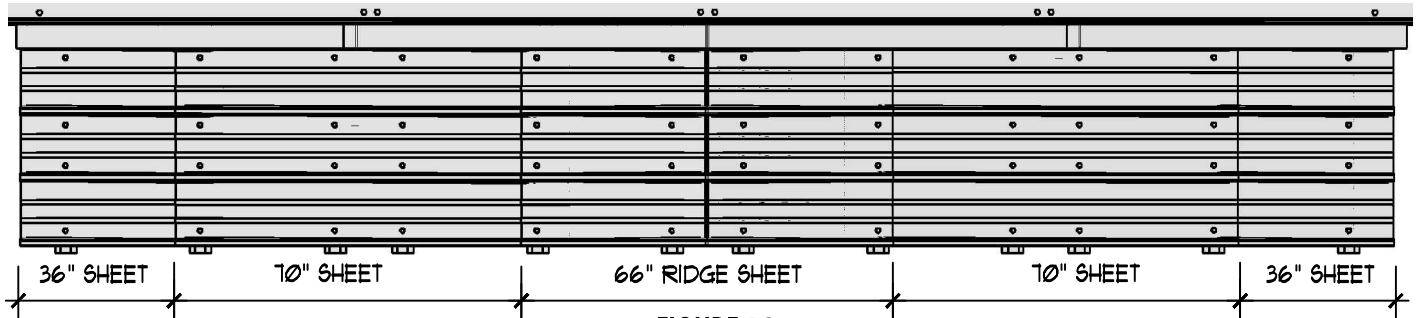

FIGURE 16

- Place the Ridge Roof Sheet (C-041-00) back on the canopy. Center it to make sure it is under the Transition Flashing and centered on the ridge. Using the Structural Screws (F-051-00) fasten to the Hat Purlins per **Figure 16**. Using the roll of Tape Sealant, apply to the last major roof panel corrugation under the Transition Flashing from eave to eave. Remove paper and secure the Transition Flashing to the Roof Sheets with Stitch Screws (F-051-00) 6" on center.
- Apply another strip of Tape Sealant on the outer most major rib of the roof sheet. Place the Rake Trim Ends in place as shown in **Figure 17**.

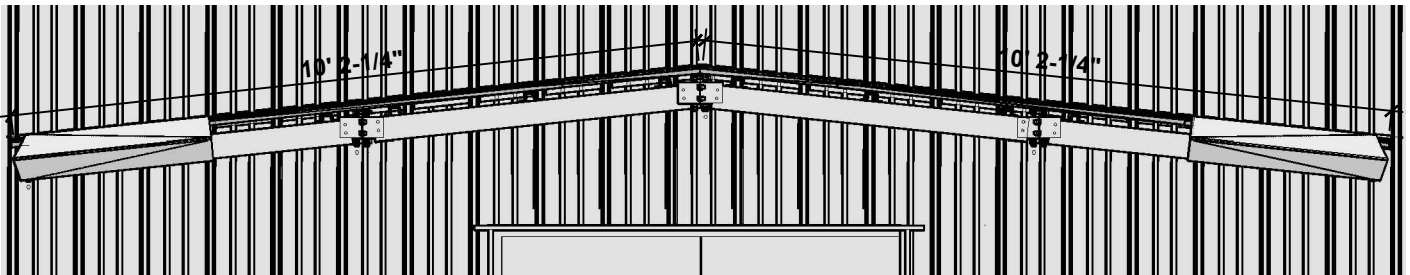

FIGURE 17

- Install the Center Rake Trim (straight cut on both ends), line up with the center of the roof sheet and press the right side on to the tape sealant. Attach the right side with Stitch Screws (F-051-00) 6" on center.

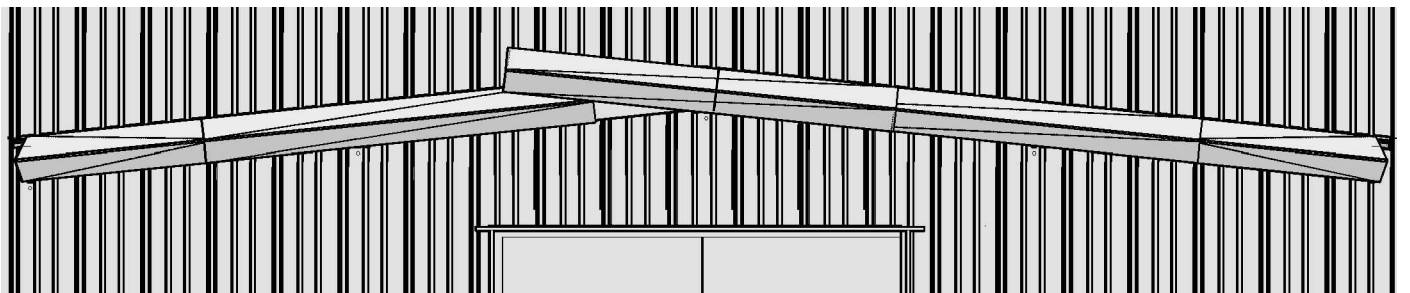

FIGURE 18

- On the center mark, cut the Rake Trim from the bottom to the top horizontal leg. Slide the right side behind the left and press the Rake Trim into place upon the Tape Sealant on the Roof Panel (**Figure 18**). This cut does not have to be perfect because it will be covered with the Peak Plate (T-034-00). Attach the right side of the Rake Trim with Stitch Screws 6" on center. Use Pop Rivets for Rake Trim end laps.

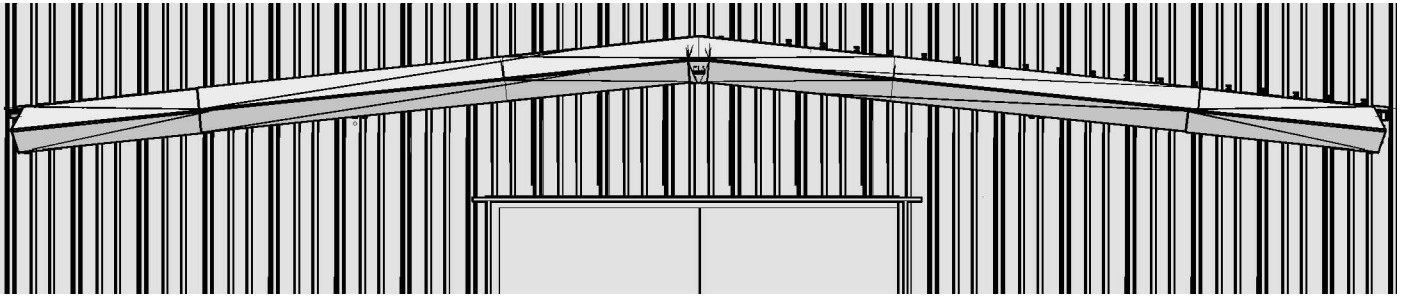

FIGURE 19

7. Measure the distance from the Rake Trim to the wall panel to determine the length of Right/Left Eave Trim. Notch around panel ribs as required to fit tightly against the wall. Cut each side separately due to wall panel rib locations. Align the center line of the trims and attach the Eave Trim to the Rake Trim using Pop Rivets (F-053-00), (4) per connection. Install a Foam Inside Closure on top of the Eave Trim and under the Roof Panel. Square the Eave Trim with the Roof Panel and install Structural Roof Screws through the Roof Panel, Eave Trim and Horizontal Channel.

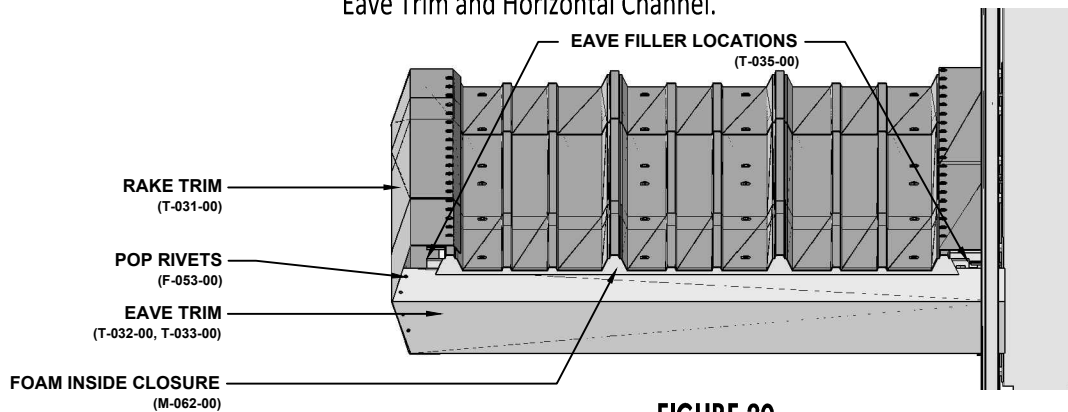

FIGURE 20

8. Cut a piece from the Eave Filler (T-035-00) to fill in the gaps shown in Figure 18. Attach with Pop Rivets or Stitch Screws from below.
9. Attach Peak Plate (T-034-00) over the cut at the center of the Rake Trim using (4) Pop Rivets.

c. Soffit Sheets

1. Option #1 - If you have outside foam closures matching your wall panel configuration, attach Soffit "F" Trim (T-037-00) with foam closures to the wall panel following the line of the underside of the canopy framing. Cut Soffit Sheet to span from Soffit "F" Trim to the bottom leg of the Rake Trim. Attach each Soffit Sheet (C-044-00) with (4) Soffit Screws (F-054-00) to the underside of the Gable Channels. The Soffit Panels can be easily cut with a tin snips.
2. Option #2 - Cope the Soffit Sheet ends to match the configuration of the wall panel. When you have it so it fits nicely to the wall, cut the front end so that it will lie on the Rake Trims bottom leg. Attach Each Soffit Sheet with (4) Soffit Screws to the bottom of the Gable Channels.

7. Clean Up

- a. Using a broom, sweep any metal chips off the roof. The Kynar500/Hylar 5000 Fluoropon Paint is very durable and if you have any marks or dirt on your roof or trim, it normally can be removed with water and a rag.

